

PRONUNCIATION

ONE TO ONE



Mark Hancock



1 Mind the spelling traps



2 Beware the pitfall pairs



5 Listen between the lines

HOMESTAY PRON

Top Five Priorities

3 Grab the grammar



4 Connect it up

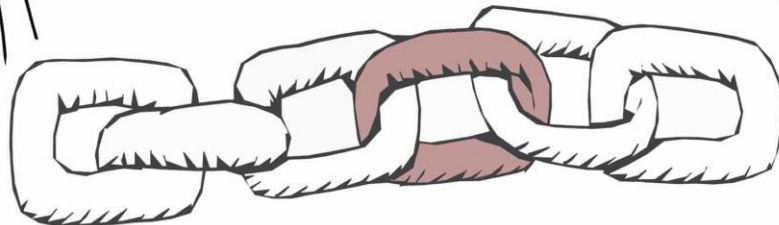

U MAZE

Go from RUN to FUN only passing words with that vowel sound. There may be dead ends!

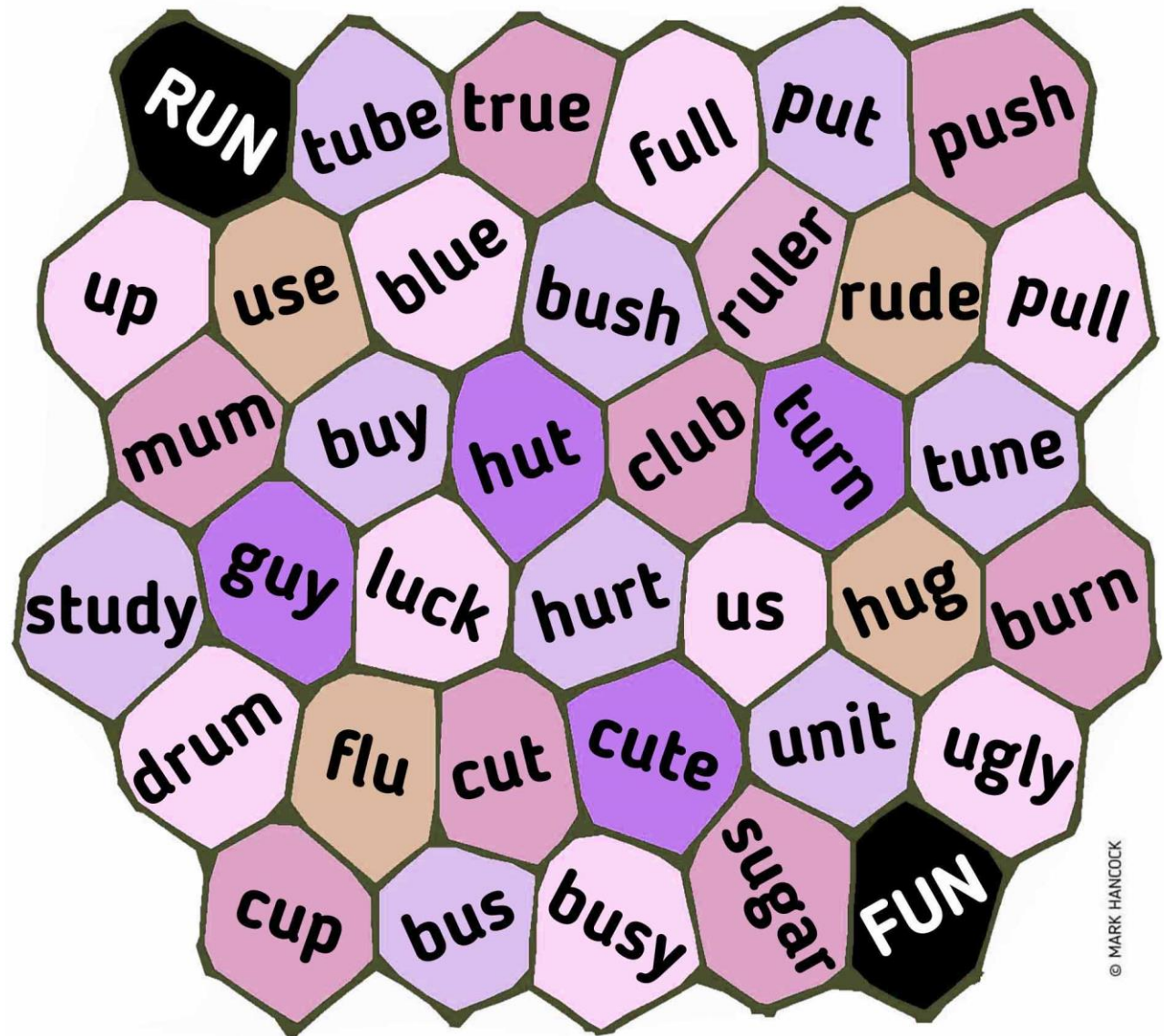

© MARK HANCOCK

SPELLING TRAPS

Comfortable,
madam?



No no,
come for food!

SPELLING TRAPS

THERE'S NO 'TABLE' IN 'COMFORTABLE'!

I **knew** a young **woman** called **Mabel**
Who **slept** on a **kitchen table**
Made herself **comf^{or}table**
Head on a **veg^etable**
Never knew **how** she was **able**!



SPELLING TRAPS

Worked in a factory

Did whatever necessary

Started off in January

Laid off in February

Worked as a secretary

That was only voluntary

That's my work history

Future's still a mystery



INPUT:

Gloucester
Leicester
Worcester



PROCESS:

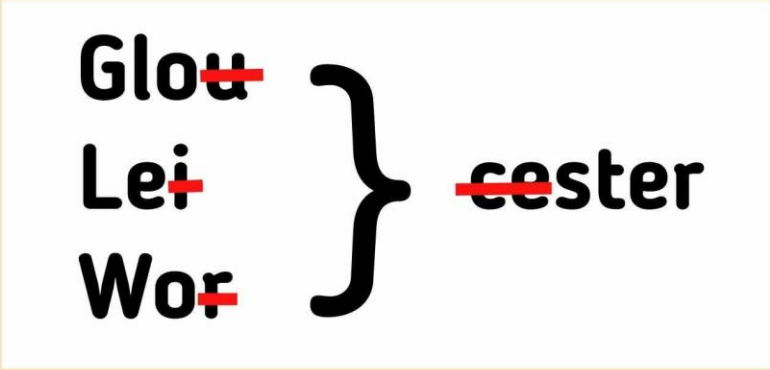

OUTPUT:

"Gloster"
"Lester"
"Woster"



(wo like woman)

**OFFICE
LIFE**

Hey Ana,
got any paper?

Sure Jim, you
wanna piss?



Eh, no, just some
paper, please!



Yes, a piss
of paper - just
one shit?

© MARK HANCOCK

PITFALL PAIRS

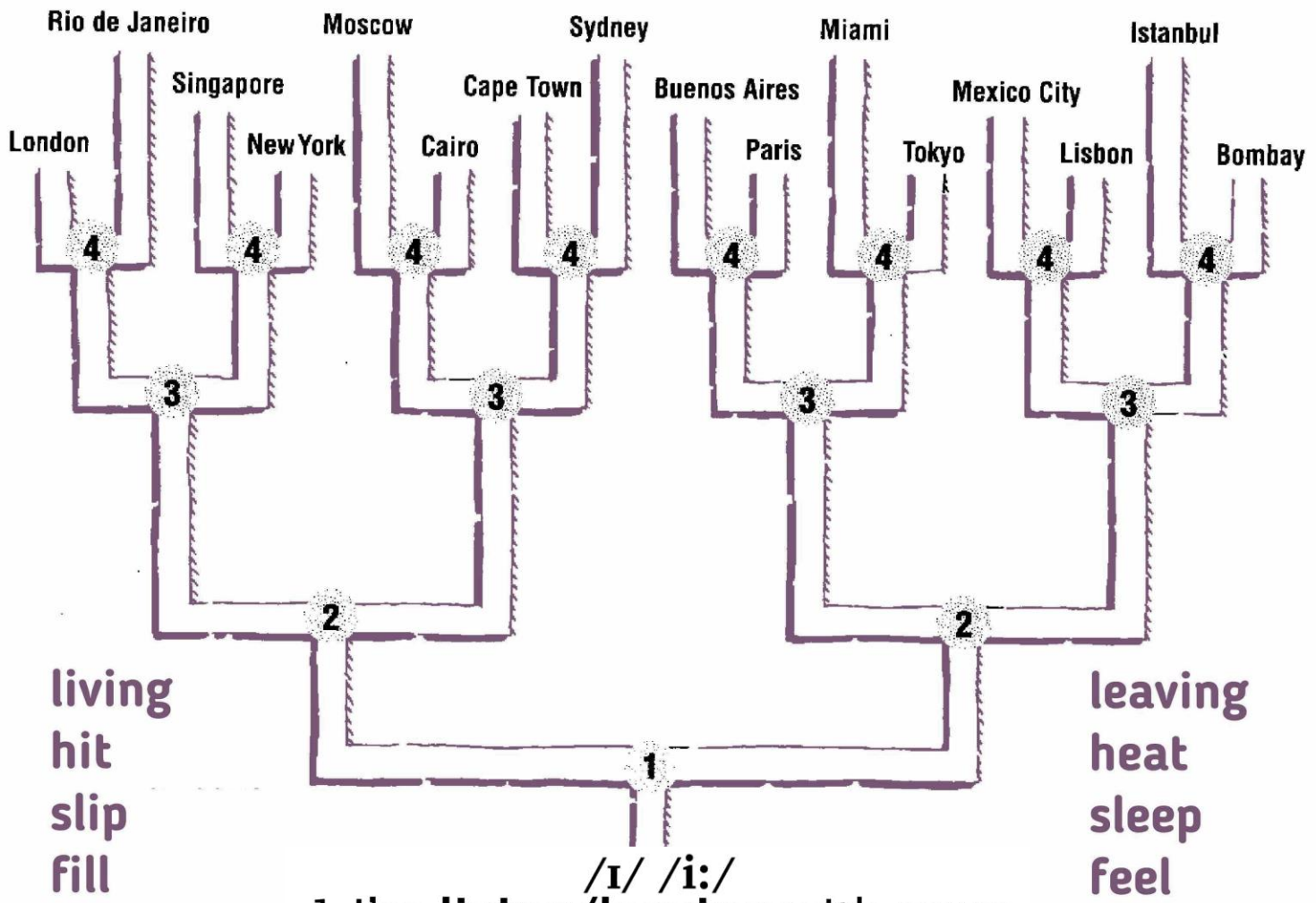

living
hit
slip
fill

leaving
heat
sleep
feel

/ɪ/ /i:/
1

- 1 I'm **living/leaving** with mum.
- 2 Don't **hit/heat** the plates.
- 3 Don't **slip/sleep** on the ice.
- 4 Can you **fill/feel** it?

PITFALL PAIRS

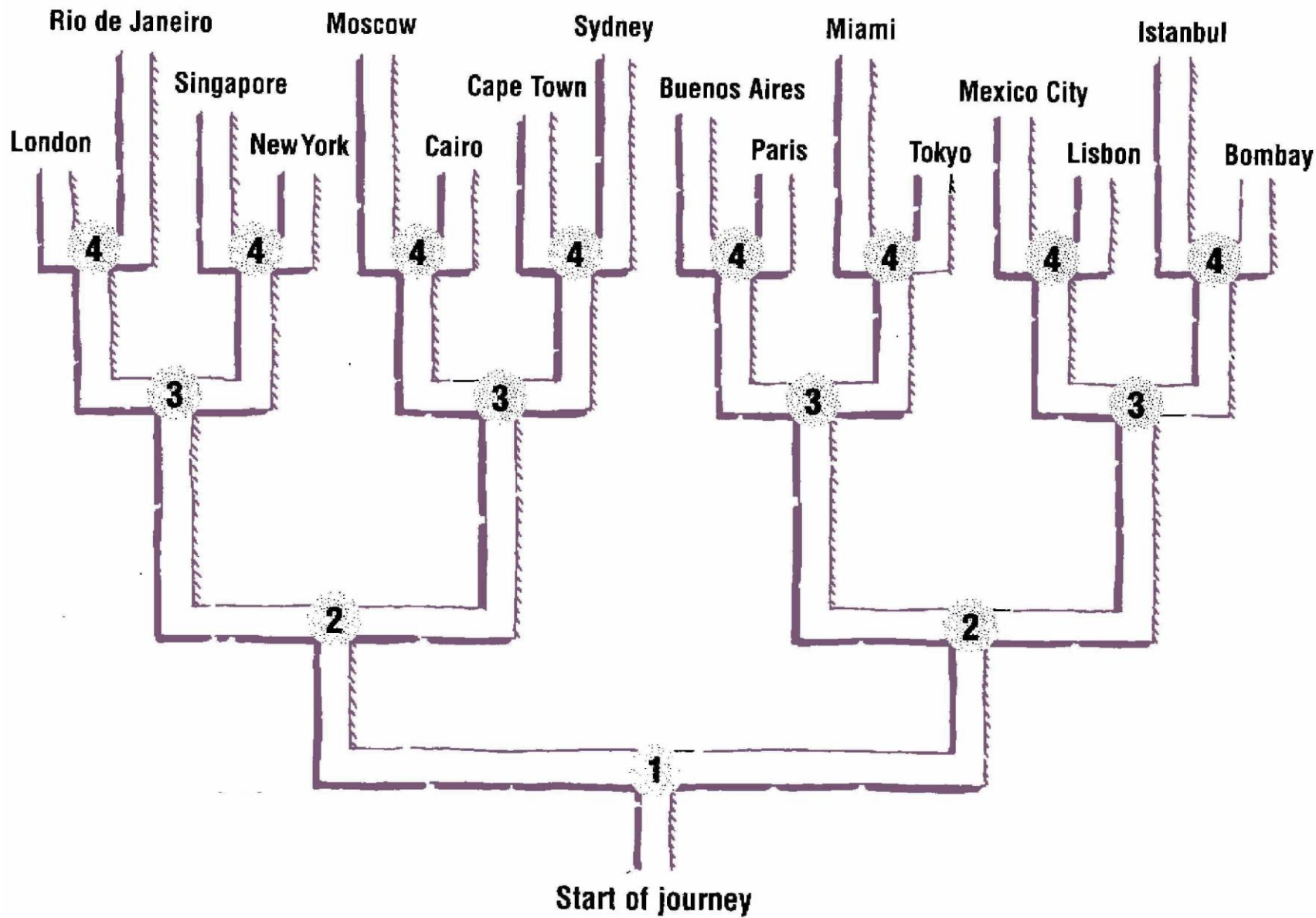

VOWEL MINIMAL PAIRS

/ɪ/ /i:/

- 1 I'm **living/leaving** with mum.
- 2 Don't **hit/heat** the plates.
- 3 Don't slip/sleep on the ice.
- 4 Can you **fill/feel** it?

/æ/ /e/

- 1 Where did the **man/men** go?
- 2 This **pan's/pen's** leaking!
- 3 It's **sad/said** that she died young.
- 4 We're on the wrong **track/trek**!

/e/ /eɪ/

- 1 We **rest/raced** in our cars.
- 2 Have you **tested/tasted** the wine?
- 3 My dad **sells/sails** boats.
- 4 There's a **pen/pain** in my hand.

/ɔ:/ /əʊ/

- 1 I **walk/woke** early in the morning.
- 2 Anybody **called/cold** this morning?
- 3 There's a mouse in the **hall/hole**!
- 4 She's **pausing/posing** for a photo.

/ɒ/ /əʊ/

- 1 We got a **cot/coat** for the baby.
- 2 They would have **none/known** of it.
- 3 They **want/won't** sleep.
- 4 What a great **honour/owner**!

/æ/ /ʌ/

- 1 There's a **cat/cut** on the sofa!
- 2 I **ran/run** for half an hour.
- 3 I colled coins in my **cap/cup**.
- 4 I didn't enjoy that **match/much**.

Vowels 4 and 3, /æ/ versus /e/

	i	I	e	æ	a
i	*	466	331	391	31
I	4	*	449	639	22
e	4	5	*	305	14
æ	2	3	5	*	18
a	2	2	2	4	*

access excess
 ad Ed
 ad-man ad-men
 added eddied
 affluent effluent
 affluents effluents
 Al L
 Alf elf
 Ali Ellie
 alimentary elementary
 Allan Ellen
 allergy elegy
 allergies elegies
 am M
 amber ember
 and end
 Ann N
 Annfield Enfield
 Annie any
 areca Erica
 arrant errant
 aster Esther

PITFALL PAIRS

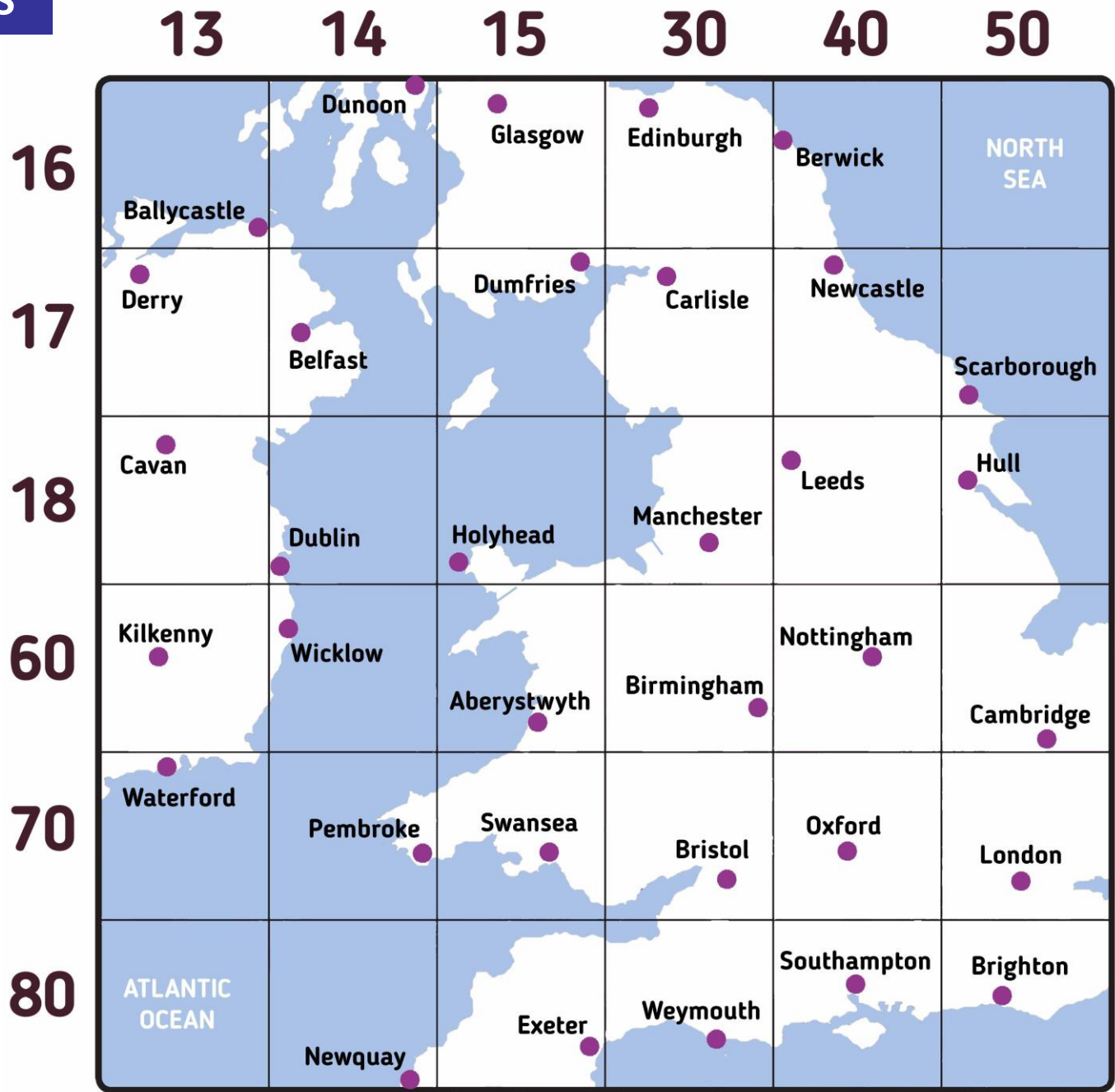

PITFALL PAIRS

bean

chip

feet

bin

fit

cheap

feel



sit



live



fill



seat



leave

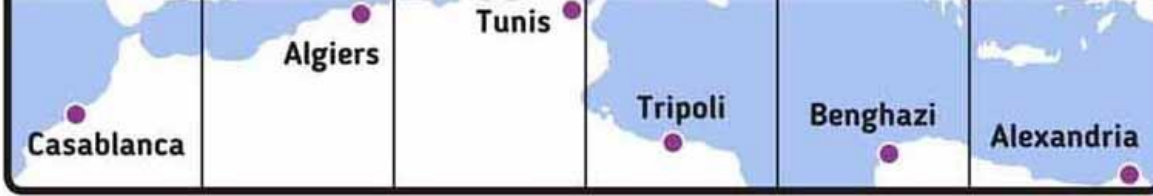

PITFALL PAIRS

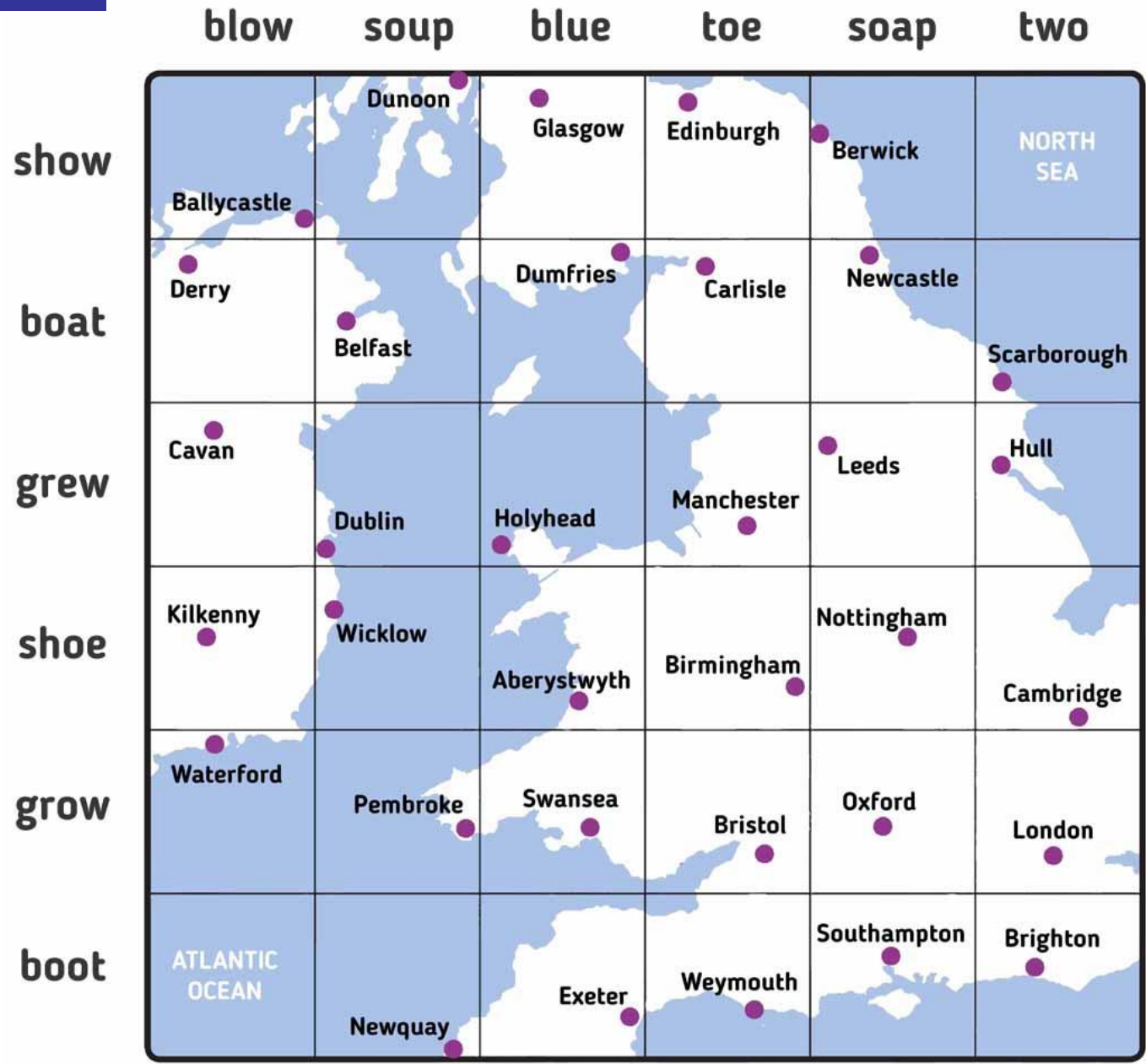

From PronPack 3: Pronunciation Pairworks

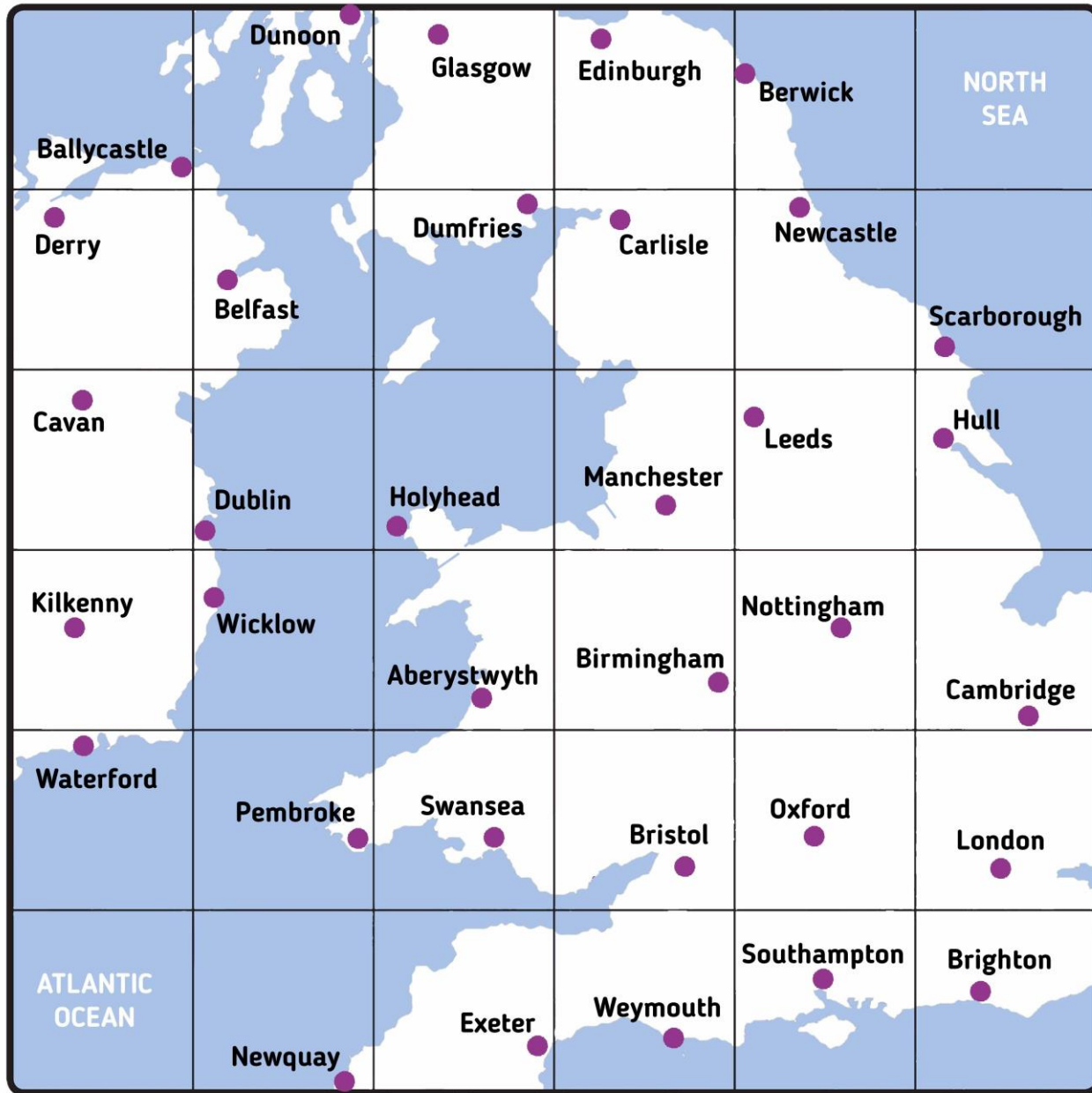



After
he, she or it ...

	A ADD -ES	talk	draw	cook		
	teach	count	run	watch	wish	
	walk	wash	drink	press	text	guess
clean	mix	keep	catch	laugh	fix	look
	switch	break	push	buy	search	play
	dress	kiss	help	hold	finish	
	start	stop	end	B ADD -ES		

© MARK HANCOCK

-ED = /ɪd/

start	need	wait	knock	close
stop	cook	taste	walk	like
work	hate	lift	help	love
clean	want	shop	dress	wash
play	shout	text	add	end

start				
				end

-ED = /ɪd/

start	need	wait		
		taste		
	hate	lift		
	want			
	shout	text	add	end

Odd-one-out?

ached
baked
braked
naked
faked

A		B
LOCKET	LANE	
	C	D
LOCKED	LANE	
E	F	
	LIVED ROAD	
	G	H
	LIVID ROAD	

PHILLID STREET

FILLED STREET

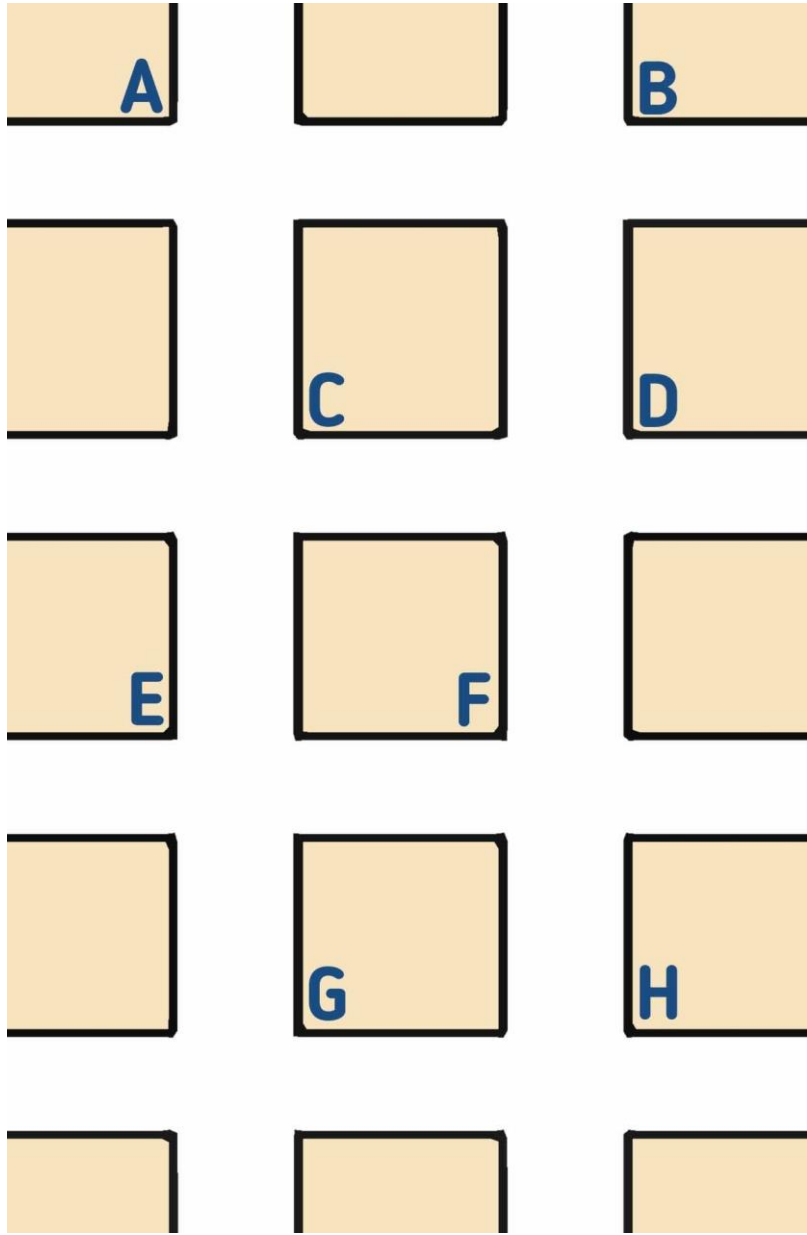

Knocked and **waited**
Closed and **locked**
Wanted it to **open**
Waited, **knocked**

SOUNDS LIKE...

nock tan way tid
close dan lockt
wan tiditoo wopen
way tid nockt



NIGHTMARE HOTEL

I walk up the hill
To the Nightmare hotel
I stop at the door
But I couldn't see the bell

I knock an I wait id
In the cold and windy night
I look in the window
But there wasn't any light

That's when I not ist
The door was open wide
Then it start id raining
So I walk inside

The door clos ed behind me
I ask t, 'Who's there?'
That's when I not ist
The rats on the stairs

I turn around to leave
But I couldn't see the door
That's when I not ist
The body on the floor

Then the body mov ed
The woman wasn't dead
She told me her story
This is what she said...



BRICKS OR CEMENT?



Content words	Function words
nouns (eg <i>hour, tea</i>)	prepositions (eg <i>to, for</i>)
main verbs (eg <i>play, wait</i>)	the verb <i>to be</i> (eg <i>is, are, was</i>)
adjectives and adverbs (eg <i>good, quickly</i>)	auxiliary verbs (eg <i>can, does</i>)
question words (eg <i>who, what</i>)	articles (eg <i>an, the</i>)
contractions with <i>not</i> (eg <i>can't, isn't</i>)	conjunctions (eg <i>and, or</i>)
	personal pronouns (eg <i>you, her</i>)

1

2

3

4

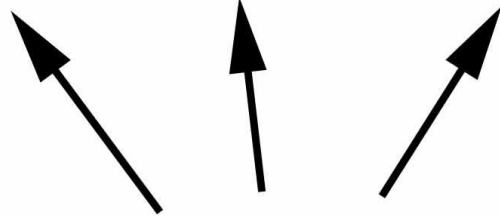

and her

ana

of his

aviz

'll be

albi

has been

azbin

can be

cambi

could be

cubbi

isn't

izan'

WEATHER RHYME

Whether the **w**ea**th**er **w**as **g**ood (4)
1 2 3
Or **w**h**e**ther the **w**ea**th**er **w**as **b**ad (4)
1 2 3
The **w**ea**th**er **w**as **b**etter
1 2
When **w**e **w**ere to**g**ether
3 4
Wha**te**ver the **w**ea**th**er **w**e **h**ad (4)
1 2 3





Give them a Search Say it!

All US UK AUS

How to pronounce **Give them a** in English (7 out of 13698):

Best Books of 2019!

Watch Later Share

MORE VIDEOS

20:23 / 25:03

Speed: normal

then please do **give them a** go. We're down to

LISTEN

Which lines
have the 'th'
cut in 'them'?

- 1 and so we **give them a** chance
- 2 if we **give them a** chance
- 3 **give them a** place
- 4 so if you'd like to **give them a** try
- 5 we try to **give them a** band
- 6 to **give them a** go
- 7 and they didn't **give them a** lot of attention
- 8 and he'll just **give them a** hug
- 9 **give them a** tiny bit of pain
- 10 **give them a** tool to do something
- 11 and **give them a** click
- 12 **give them a** fair and equal opportunity
- 13 **give them a** copy of my book
- 14 that we just **give them a** pass
- 15 I **give them a** bit of a thought experiment
- 16 but if you **give them a** basic idea you know
- 17 they **give them a** lot to do
- 18 you **give them a** hug
- 19 let's **give them a** certification
- 20 and we want to **give them a** big big beautiful
round of applause

1. Finished or to be continued?

2. Telling, asking or checking?

3. Certain or unsure?

4. Tentative or emphatic?

INVITING

START

What are you doing at the weekend?

Are you doing anything on Friday evening?

Well, I'm going out on Saturday but I'm free on Friday

Oh, nothing much. Why?

Well, I'm a bit busy actually. Why?

Would you like to come round and see my photos?

How about going out for something to eat?

I'm having a party. Do you want to come?

Do you fancy going to the cinema?

I'd love to. What time?

Well, I'd prefer not to. I'm on a diet.

I'd rather not. I have to get up early in the morning.

Let's meet around 8 o'clock.

OK then. Maybe some other time.

FINISH



4.1 Get up on your Feet

You **won't** get **fit**
Just **sitting** on a **seat**
If you **wanna** get **fit**
Gotta **get** up on your **feet**



Don't **fill** that **seat**
Gotta **move** a little **bit**
Kick your **feet** to the **beat**
Feel the **heat**, that's **it!**



MARK HANCOCK: BOOKS

